

and adding the ester, followed by indicator and a measured amount of base. Enough base was added to put the indicator on the basic side and then the time at which the solution became acidic was noted. At this point, another portion of base was added to make the solution basic and the color change again noted with time. Mean deviation of five runs using this method varied from 5 to 10%.

References and Notes

- (1) Postdoctoral research associate on a grant supplied by Exxon Research and Engineering Co.
- (2) Postdoctoral research associate on Project No. AT(11-1)70 supported by the Atomic Energy Commission.
- (3) Purdue University postdoctoral research associate.
- (4) H. C. Brown (with comments by P. v. R. Schleyer), "The Nonclassical Ion Problem," Plenum Press, New York, N.Y., 1977.
- (5) S. Winstein and D. Trifan, *J. Am. Chem. Soc.*, **74**, 1147, 1154 (1952).
- (6) P. v. R. Schleyer, M. M. Donaldson, and W. E. Watts, *J. Am. Chem. Soc.*, **87**, 375 (1965).
- (7) S. Winstein, *J. Am. Chem. Soc.*, **87**, 381 (1965).
- (8) J. E. Nordlander, R. R. Gruetzmacher, W. J. Kelly, and S. P. Jindal, *J. Am. Chem. Soc.*, **96**, 181 (1974).
- (9) J. L. Fry, J. M. Harris, R. C. Bingham, and P. v. R. Schleyer, *J. Am. Chem. Soc.*, **92**, 2540 (1970).
- (10) J. M. Harris and S. P. McManus, *J. Am. Chem. Soc.*, **96**, 4693 (1974).
- (11) B. Capon and S. P. McManus, "Neighboring Group Participation", Vol. 1, Plenum Press, New York, N.Y., 1976, Chapter 1.
- (12) H. C. Brown and K. Takeuchi, *J. Am. Chem. Soc.*, **99**, 2679 (1977).
- (13) D. G. Farnum and G. Mehta, *J. Am. Chem. Soc.*, **91**, 3256 (1969).
- (14) In cases where the aromatic ring contains deactivating substituents, the authors have observed changes in the NMR spectra which they believe may indicate the beginning of some kind of electronic interactions (non-classical?): D. G. Farnum and A. D. Wolf, *J. Am. Chem. Soc.*, **96**, 5166 (1974).
- (15) H. C. Brown, F. J. Chloupek, and M.-H. Rei, *J. Am. Chem. Soc.*, **86**, 1248 (1964).
- (16) H. C. Brown, I. Rothberg, P. v. R. Schleyer, M. M. Donaldson, and J. J. Harper, *Proc. Natl. Acad. Sci. U.S.A.*, **56**, 1653 (1966).
- (17) See ref 4, Chapter 8.
- (18) H. C. Brown, *Acc. Chem. Res.*, **6**, 377 (1973).
- (19) For a contrary opinion, see discussion by P. v. R. Schleyer, ref 4, p 217.
- (20) (a) T. W. Bentley and P. v. R. Schleyer, *J. Am. Chem. Soc.*, **98**, 7658 (1976); (b) F. L. Schadt, T. W. Bentley, and P. v. R. Schleyer, *ibid.*, **98**, 7667 (1976).
- (21) J. M. Harris, D. J. Raber, W. C. Neal, Jr., and M. D. Dukes, *Tetrahedron Lett.*, 2331 (1974); D. J. Raber, M. D. Dukes, and J. Gregory, *ibid.*, 667 (1974).
- (22) J. M. Harris, D. L. Mount, M. R. Smith, and S. P. McManus, *J. Am. Chem. Soc.*, **99**, 1283 (1977).
- (23) F. L. Schadt, P. v. R. Schleyer, and T. W. Bentley, *Tetrahedron Lett.*, 2335 (1974).
- (24) Private communication, D. Lenoir. For brosylates see D. Lenoir, W. Röll, E. Welss, and G. Wenke, *Tetrahedron Lett.*, 1991 (1976).
- (25) To be reported jointly with T. W. Bentley.
- (26) C. F. Wilcox, private communication.
- (27) G. A. Olah, *Acc. Chem. Res.*, **9**, 41 (1976).
- (28) J. L. Fry, C. J. Lancelot, L. K. M. Lam, J. M. Harris, R. C. Bingham, D. J. Raber, R. E. Hall, and P. v. R. Schleyer, *J. Am. Chem. Soc.*, **92**, 2538 (1970); P. v. R. Schleyer, J. L. Fry, L. K. M. Lam, and C. J. Lancelot, *ibid.*, **92**, 2542 (1970).
- (29) Reference 4, p 217.
- (30) J. M. Harris, D. L. Mount, and D. J. Raber, *J. Am. Chem. Soc.*, preceding paper in this issue.
- (31) R. A. Snee, *Acc. Chem. Res.*, **6**, 46 (1973).
- (32) However, as was pointed out earlier in this paper, Winstein later suggested that σ bridging may lag behind ionization. See ref 7. If this were the case, it is not clear whether the solvolysis should be considered to be a k_{Δ} or k_c process.
- (33) See ref 4, Chapter 7.
- (34) R. S. Tipson, *J. Org. Chem.*, **9**, 235 (1944).
- (35) R. E. Robertson, *Can. J. Chem.*, **31**, 589 (1953).
- (36) H. C. Brown and G. Ham, *J. Am. Chem. Soc.*, **78**, 2735 (1956).
- (37) M. M. Donaldson, Ph.D. Thesis, Princeton University, 1958.
- (38) H. R. Williams and H. S. Mosher, *J. Am. Chem. Soc.*, **76**, 2987 (1954).
- (39) T. Tsuji, T. Komeno, H. Itanli, and H. Tanida, *J. Org. Chem.*, **36**, 1648 (1971).
- (40) S. Winstein and E. Grunwald, *J. Am. Chem. Soc.*, **70**, 846 (1948).
- (41) S. Winstein and R. Heck, *J. Am. Chem. Soc.*, **78**, 4801 (1956).
- (42) H. C. Brown, R. Bernheimer, C. J. Kim, and S. E. Scheppele, *J. Am. Chem. Soc.*, **89**, 370 (1967).

On the Role of Newman Projections in Conformational Analysis. Evidence for Nonalternating Ground States in Highly Strained Molecules

W. Douglas Hounshell, Dennis A. Dougherty, and Kurt Mislow*

Contribution from the Department of Chemistry, Princeton University, Princeton, New Jersey 08540. Received July 18, 1977

Abstract: Newman projections of substituted ethanes are commonly assumed to display a regular alternation of front and back substituents. However, symmetry arguments lead to the conclusion that the torsional itineraries of even the most simply substituted ethanes must involve conformations which do not exhibit this alternation. Empirical force field calculations show that the ground state conformations of two highly strained molecules, racemic 1,2-bis(2,6-dimethylphenyl)-1,2-di-*tert*-butylethane (**1f**) and 1,1,2,2-tetra-*tert*-butylethane (**2**), have nonalternating Newman projections. An enumeration and description of the topologically distinct Newman projections perpendicular to a bond with any number of ligands is derived group theoretically.

In discussions dealing with the ground state conformations of acyclic substituted ethanes,¹ it seems to be taken for granted that the Newman projections display a regular alternation of front (F) and back (B) ligands in the sense that each F in the projection is flanked by two B's, and vice versa. To our knowledge, this tacit assumption has never been challenged. However, although F/B alternation in molecular ground states is the general rule, we intend to show that in certain cases involving sterically strained molecules this assumption breaks down, and may consequently lead to misinterpretation of experimental results and incorrect conclusions concerning the preferred conformations of such molecules. Beyond this, we shall demonstrate that on the basis of symmetry arguments alone, nonalternation is expected to be a routine occurrence

for many substituted ethanes in conformations other than those of the ground state.

Nomenclature. To facilitate our discussion, we introduce an ad hoc nomenclatural scheme which is illustrated for the nine possible ethane skeletons in Figure 1. Projections are onto a plane perpendicular to the ethane C-C bond, ligands are labeled F and B as described above, and E designates a pair of eclipsed ligands. Descriptors are obtained by reading ligand labels in a sequential order around the periphery of the projection, and that descriptor is chosen which gives the largest numeral when priority rankings 2, 1, and 0 are substituted for F, B, and E, respectively. For example, FEBE is correct, whereas EBEB, BEFE, or EFEB are not. For all but one skeleton, the equivalence of the two ethane ends assures the

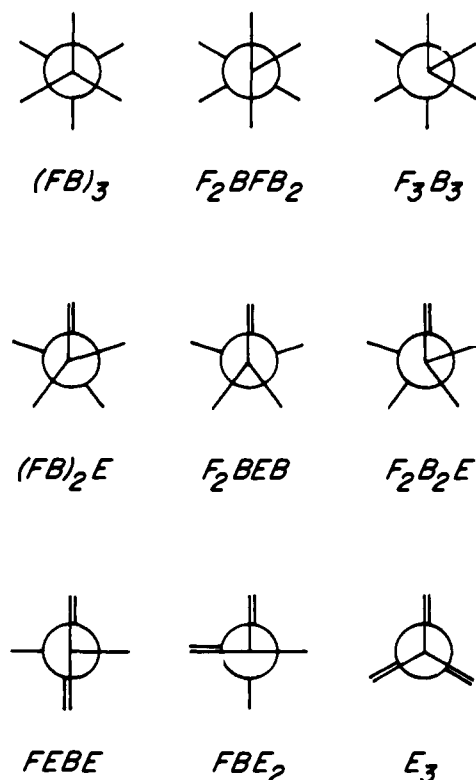

Figure 1. The nine types of Newman projections of ethane skeletons.

uniqueness of the descriptor regardless of the direction of view; the one exception is F_2BEB , which has priority over FB_2FE . Finally, we note that for an achiral skeleton the correct descriptor is obtained whether the ligand sequence follows a clockwise or a counterclockwise direction when viewed from a given end, whereas for a chiral skeleton the direction is uniquely determined by the sense of chirality. By modified use of the *re/si* nomenclature,² it is possible to characterize the chiral skeletons in Figure 1, i.e., F_2BFB_2 , $(FB)_2E$, F_2B_2E , and FBE_2 , by the prefix *re*, indicating a clockwise direction for the correct priority sequence, and the enantiomorphous skeletons (not shown) by the prefix *si*.

Application of Symmetry Arguments

Inspection of the nine structures in Figure 1 (which can be derived group theoretically, see below) reveals that only two are generally considered: the regularly alternating structure $(FB)_3$, and the fully eclipsed structure, E_3 . What is the likelihood of a substituted ethane adopting conformations other than these two in the course of a complete torsional circuit, i.e., over the full range of dihedral angles (ϕ) from 0 to 2π ? We can put the question another way: what are the conditions under which $(FB)_3$ and E_3 conformations are exclusively encountered over this range?

The answer is provided by a symmetry argument. So long as the molecular symmetry at all points along the torsional circuit contains C_3 as a subgroup, the C_3 axis perpendicular to the plane of the projection guarantees exclusive population by E_3 and $(FB)_3$ conformations; the former corresponds to three points on the energy profile, and the latter to all others. Only molecules of the types X_3C-CX_3 (including ethane itself) and X_3C-CY_3 can satisfy this condition.

In the absence of C_3 subsymmetry, exclusive population by the two classical conformations is no longer to be expected. As a simple example, consider chloroethane, whose energy profile (Figure 2a) superficially suggests conformational behavior like that of ethane. However, the crucial C_3 axis is missing, and the

highest attainable symmetry is C_s . The only valence bond angles (θ) which are expected to be equal are those which are related by a σ plane; hence $\theta(CICH) \neq \theta(HCH)$ under any circumstances, and only under conditions of highest symmetry is there pairwise equality between two CICH and two HCH angles. Consequently, since for one such conformation $\phi(CICCH) = 0$, we would expect that $\phi(HCCH) \neq 0$, i.e., when Cl and H are eclipsed, the H's are not expected to be, and when the H's are eclipsed, the Cl and H are not expected to be. It follows that although $(FB)_3$ is attainable for chloroethane, E_3 is not. Instead, eclipsing is always partial and always between a single pair of ligands at a time.

Eclipsed Conformations. The preceding analysis illustrates a powerful symmetry argument: any molecular parameters (bond lengths, bond angles, dihedral angles) which are not related by a symmetry operation of the molecule are expected to differ in magnitude.³ We can adjoin to this argument the simplifying chemical assumption that one eclipsed conformation of chloroethane (Cl/H eclipsed) has C_s symmetry and therefore belongs to F_2BEB . The symmetry of the resulting energy profile⁴ is such that this form will necessarily represent an extremum, presumably the transition state. Given the C_s symmetry of the Cl/H eclipsed form, the conformation with H/H eclipsing must be $(FB)_2E$. This form is asymmetric, and as such no special significance can be attached to its position on the energy profile, since the a priori designation of a particular structure as an energy extremum can only be made on the basis of symmetry. Thus, in a complete torsional circuit, there are three singularities with Cl/H eclipsing and six with H/H eclipsing (Figure 2a).

This analysis can be extended to include all possible ethane substitution patterns (see Table I). Conversion of one $(FB)_3$ form to another requires that three pairs of bonds become eclipsed at one time or another. Only three possibilities exist for such a transformation—the eclipsings can occur three at a time, or two at a time followed (or preceded) by a single eclipsing, or one at a time (E_3 , DS or SD, or 3S, respectively). There are four cases in which full eclipsing (an E_3 structure) is possible. The first two (X_3C-CX_3 and X_3C-CY_3) have been discussed above; the last two (X_2YC-CX_2Y and *meso*- $XYZC-CXYZ$) may exhibit a single E_3 structure corresponding to that conformation for which the plane of projection has also become a σ plane. Double eclipsing can be expected for those conformations of X_2YC-CX_2Y and racemic $XYZC-CXYZ$ possessing only a molecular C_2 axis. Single eclipsing obtains in all other cases. The X_2YC-CX_2Y system is thus unique in that singly, doubly, and fully eclipsed structures may all be involved in a complete torsional circuit. Figure 2b shows an example of such a pathway for which it has been arbitrarily assumed that E_3 and $(FB)_2E$ forms are always separated by an FBE_2 structure. A sequence could have equally well been chosen in which E_3 and FBE_2 structures are separated by $(FB)_2E$ forms.⁵

Noneclipsed Conformations. We have demonstrated that in a rotation of $2\pi/3$ radians about the central bond of chloroethane, three singularities must occur, each of which corresponds to a structure with just one pair of bonds exactly eclipsed. Let us now examine more closely the regions between these singularities. Beginning with the ground state, rotation yields only $(FB)_3$ structures until the first eclipsing is encountered ($(FB)_2E$). Continued rotation immediately destroys the eclipsing and, until the second eclipsing (F_2Beb) occurs, all conformations have nonalternating, noneclipsed structures (F_2BFB_2 , dashed line segments in Figure 2a). Continued rotation again leads to F_2BFB_2 , $(FB)_2E$, and $(FB)_3$ structures which, given the symmetry of the reaction coordinate, are the enantiomers of those encountered over the previous $\pi/3$ radians.

In general, all rotation itineraries which exhibit three singly

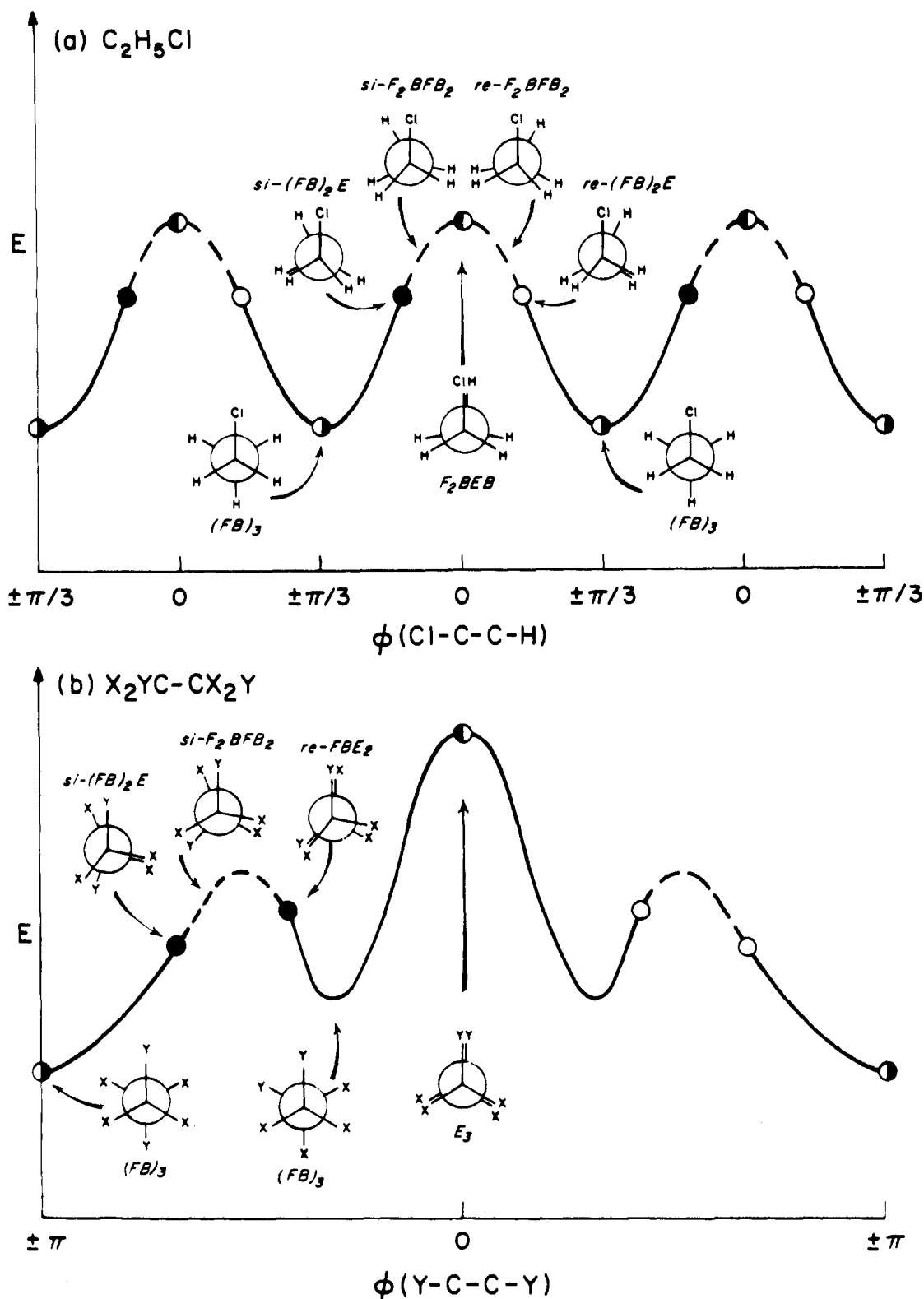
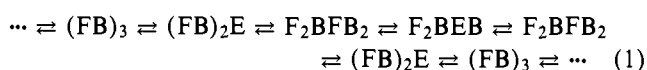

Figure 2. The complete torsional circuits for (a) chloroethane and (b) X_2YC-CX_2Y . Magnitudes of relative energies and dihedral angles ϕ (except where explicitly indicated) are arbitrary. Values of ϕ in (a) are averages of the three ClCCH dihedral angles. Filled and unfilled markers represent enantiomeric structures; half-filled markers represent achiral structures. Noneclipsed conformations are represented by solid line segments for alternating projections $((FB)_3)$ and by dashed line segments for nonalternating projections (F_2BFB_2) .

eclipsed structures between two neighboring $(FB)_3$ segments (cf. Figure 2) must follow the cycle of Newman projections described above for chloroethane (eq 1).



For rotations involving double eclipsing or full eclipsing, the

cycles in eq 2 and eq 3, respectively, apply.⁶

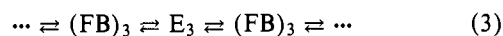
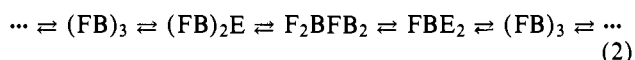

Note that the complete torsional circuit for the X_2YC-CX_2Y

Table I. Torsional Circuits of Ethanes According to Substitution Patterns

Ethane substitution pattern	Highest possible symmetry of transition states ^a	Eclipsing sequences in a complete torsional circuit ^b		
X ₃ C-CX ₃	3D _{3h}	E ₃	E ₃	E ₃
X ₃ C-CY ₃	3C _{3v}	E ₃	E ₃	E ₃
XYZC-CXYZ (meso)	C ₁ , C _s , \bar{C}_1	3S	E ₃	3S
X ₂ YC-CX ₂ Y	C ₂ , C _{2v} , \bar{C}_2	DS or SD	E ₃	SD
XYZC-CXYZ (racemic)	C ₂ , C ₂ ^r , C ₂ ^r	(DS)	(DS)	(DS) ^c
X ₃ C-CX ₂ Y	3C _s	3S	3S	3S
X ₃ C-CXY ₂				
X ₃ C-CY ₂ Z				
X ₂ YC-CXY ₂				
X ₂ YC-CX ₂ Z				
X ₂ YC-CXZ ₂	C ₁ , C _s , \bar{C}_1	3S	3S	3S
X ₂ YC-CYZ ₂				
X ₂ YC-CZ ₂ W				
X ₃ C-CXYZ				
X ₃ C-CYZW				
X ₂ YC-CXYZ	3C ₁	3S	3S	3S
X ₂ YC-CXZW				
X ₂ YC-CYZW				
X ₂ YC-CZWV				
XYZC-CXYW				
XYZC-CXWV	C ₁ , C ₁ ^r , C ₁ ^r	3S	3S	3S
XYZC-CWVU				

^a A transition state with symmetry \bar{G} is enantiomeric to one with symmetry G . Transition states with symmetries G , G' , and G'' are diastereomeric. $3G$ means three equivalent transition states with symmetry G . ^b D = doubly eclipsed; S = singly eclipsed. ^c There are a total of eight possible sequences generated by changing one or more (DS) to (SD).

system, for which both double and full eclipsing occur (Figure 2b), corresponds to a linking of the cycles in eq 2 and 3 (eq 4):

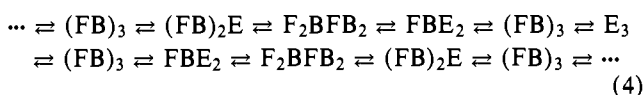

The cyclic nature of eq 2 and 3 emphasizes the fact that the sequence of eclipsings chosen for a given pathway is often arbitrary in the absence of additional, chemical evidence.

Symmetry arguments thus lead to the conclusion that all substituted ethanes, except for those of the X₃C-CX₃ and X₃C-CY₃ types, must at some point along a complete torsional circuit encounter nonalternating, F₂BFB₂ Newman projections (e.g., dashed lines in Figure 2). However, as is always the case with discussions based on symmetry, no conclusions can be drawn concerning the relative importance of such forms as applied to practical chemical problems. Such judgments must await further information of a more physical nature.

Ground State Structures

We have shown that the complete torsional circuits for the majority of ethane substitution types contain segments corresponding to conformations with nonalternating Newman projections (e.g., F₂BFB₂), in addition to segments with conventional alternating projections (i.e., (FB)₃). Although the ground states of acyclic ethanes generally fall within (FB)₃ segments, there is no reason in principle why a nonalternating segment should not also be able to encompass a ground state. We now report results of empirical force field (EFF) calcula-

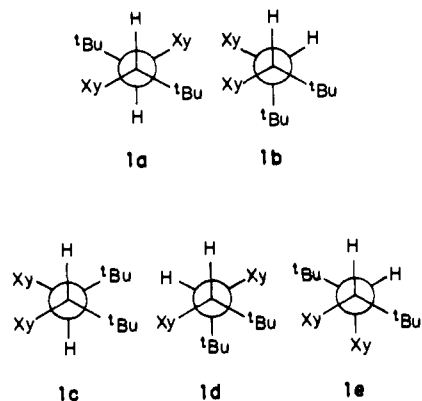

Figure 3. Idealized (FB)₃ conformations of *meso*-**1** (a and b) and racemic **1** (c, d, and e). Only one enantiomer is shown for **1b**-**e**. Xy = 2,6-dimethylphenyl.

tions on two highly strained 1,1,2,2-tetrasubstituted ethanes which predict the existence of just such nonalternating ground state structures.

1,2-Bis(2,6-dimethylphenyl)-1,2-di-tert-butylethane (1). There has been much recent interest in the conformational preferences of 1,1,2,2-tetrasubstituted ethanes.⁷⁻¹¹ In connection with our studies on 1,1,2,2-tetraarylethanes⁸ and other more highly congested ethanes,¹² we were intrigued by the conclusions of Reuvers et al.¹³ that *meso*-**1** exists in a conformation similar to **1a** while racemic **1** prefers a conformation resembling **1e** (see Figure 3). The experimental basis for these conclusions included coupling constant¹⁴ data (³J_{HH}(*meso*) = 12, ³J_{HH}(racemic) = 5 Hz), as well as chemical shift data which suggested that the xylyl groups were gauche to one another in racemic **1**. These results were considered¹³ reasonable since in both **1a** and **1e** the bulky *tert*-butyl groups are anti.

In order to investigate these results further, we performed EFF calculations on **1**. The force field used was basically the one described by Allinger in 1971,¹⁵ modified by the addition of parameters for treating aryl substituents.^{16,17} The excellent results previously obtained with this force field as applied to polyarylethanes⁸ and -methanes,¹⁸ as well as to saturated hydrocarbons,¹⁹ inspired confidence in the reliability of the EFF calculations for **1**. Five input structures (**1a**-**e**, see Figure 3)²⁰ were relaxed using the pattern search minimization technique, with an energy criterion of 0.01 kcal/mol over one iteration. The full relaxation method was used, and the structures were optimized without symmetry constraints.

Each of the five input structures relaxed to a unique minimum. As shown in Table II, the anti conformation, with the H-C_e-C_e-H dihedral angle equal to 172°, is the more stable for the *meso* isomer, consistent with the experimental results.¹³ Since the gauche form is calculated to be at least 7 kcal/mol less stable, only the anti conformation is expected to be significantly populated at normal temperatures.

For the racemic isomer the calculated ground state conformer with the *tert*-butyl groups anti is found to be the *least* stable, contrary to the previous conclusion.¹³ Instead, the most stable conformer, obtained from the input structure with the hydrogens anti (**1c**), has structure **1f**. The molecule has C₂ symmetry, the central bond length is 1.593 Å,²¹ and the H-C_e-C_e-H dihedral angle is 112°. The extended central bond and the value of the C_e-C_e-C_b valence bond angle (124.7°) reveal that **1f** is a highly strained structure.²² Nevertheless, the relative strain energies (Table II) clearly indicate that **1f** is the only significantly populated conformer for the racemic form.

As Figure 4 shows, the Newman projection of **1f** is of the F₂BFB₂ type.²³ The C₂ symmetry of **1f** and the proximity of the vicinal xylyl groups are consistent with the ¹H NMR re-

Table II. Calculated Strain Energies of Conformations of **1**

Input ^a	Newman Projection			Calcd structure (ethane dihedral angles) ^b	Rel strain energy, kcal/mol
	R ₁	R ₂	R ₃		
				Meso	
1a	Xy	H	<i>t</i> -Bu	Anti	0.0 ^c
1b	H	<i>t</i> -Bu	Xy	Gauche	7.25
				(83, -19, 86, -63, 39, -70)	
				(66, -27, 67, -97, 60, -43)	
				Racemic	
1c	<i>t</i> -Bu	H	Xy	1f	0.27
				(See Figure 4)	
1d	Xy	<i>t</i> -Bu	H	Xy anti	10.26
				(64, -26, 139, -25, 65, -41)	
1e	H	Xy	<i>t</i> -Bu	<i>t</i> -Bu anti	20.24
				(69, -32, 66, -94, 66, -32)	

^a See ref 20 and Figure 3. Xy = xylyl (2,6-dimethylphenyl). ^b Dihedral angles (in degrees) listed in the order HCCR₁, R₁CC(*t*-Bu), (*t*-Bu)CCR₂, R₂CCXy, XyCCR₃, R₃CCH. ^c Total steric energy (see eq 1 in ref 16) = 34.55 kcal/mol.

sults.¹³ According to the Karplus relation¹⁴ an H-C_e-C_e-H dihedral angle of 112° is compatible with the observed¹³ value of 5 Hz for ³J_{HH}. Nonalternating structure **1f** is thus in agreement with all the experimental data for racemic **1**, and we feel confident that it is a good representation of the ground state conformation.

1,1,2,2-Tetra-*tert*-butylethane (2). The synthesis and NMR properties of **2** have recently been reported.⁷ The structure, calculated by Rüchardt and co-workers¹¹ by use of the Allinger 1971¹⁵ and Schleyer¹⁹ EFFs, is similar to **1f**. We have performed additional calculations on **2** using four EFFs in current use, and the results are summarized in Table III.²⁶ The 1971¹⁵ and 1973²⁷ Allinger force fields predict very similar, nonalternating structures of the type F₂BFB₂. It is interesting to note that the C-C bond lengths (Table III) calculated using the Allinger 1973 EFF are only slightly longer than those using the Allinger 1971 EFF, even though only the former has a cubic (anharmonic) term in its C-C stretching function. The Schleyer EFF¹⁹ yields a structure with the same general features as the Allinger fields, although the hydrogens and *tert*-butyls are more nearly eclipsed in the Schleyer minimum. The fourth EFF, MUB-2,²⁸ yields an energy minimum with normal alternation of substituents in the Newman projection, i.e.,

Table III. Calculated Structural Parameters^a for **2**

EFF	α	β	γ	δ	C _e -C _e	C _e -C _{b(1)}	C _e -C _{b(2)}	C _b -C _e -C _b
Allinger 1971 ^b	3.6	-94.1	-70.1	97.9	1.600	1.595	1.584	119.7
Allinger 1973	3.2	-94.2	-72.2	96.9	1.604	1.608	1.590	119.3
Schleyer ^c	0.2	-99.8	-66.6	96.9	1.598	1.596	1.587	120.0
MUB-2	-11.5 ^d	-115.2	-55.4	94.7	1.650	1.625	1.588	117.9

^a Notation: e = ethane; b(1) = quaternary carbon in *t*-Bu(1); b(2) = quaternary carbon in *t*-Bu(2). ^b These values are those reported by Rüchardt and co-workers in ref 11. The values of β, γ, and δ are calculated from the values given in ref 11: α = 3.6°, 2α - β = 101.3°, γ - δ + α = -164.4°. ^c These structural parameters are essentially the same as those reported in ref 11, using the same force field. ^d With a negative α (the sign of a dihedral angle is as defined in ref 12) the projection is alternating, with the two *t*-Bu(1) groups anti, and the two methine H's gauche.

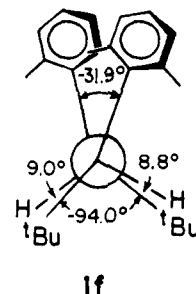
Figure 4. Calculated ground state structure (**1f**) of (*RR*)-**1**.

(FB)₃. However, this structure has unusually long C-C bonds which appear to be unreasonable¹² in light of the relative thermal stability of **2**.^{11,29} This bond lengthening represents an alternative to gross angle deformation (see C_b-C_e-C_b in Table III) as a method of relieving adverse nonbonded repulsions. We note in this connection that MUB-2 also predicts a smaller angle distortion for di-*tert*-butylmethane even though the bond lengths calculated are comparable for the four fields.³⁰ We therefore feel that the structures obtained from the first three force fields better represent the preferred conformation of **2**. As in the case of racemic **1**, the predicted F₂BFB₂ conformation of **2** is in agreement with all the experimental facts (C₂ symmetry⁷ and ³J_{HH} < 2 Hz³²).

Vicinal Relationships. For nonalternating F₂BFB₂ ground states, a description in terms of gauche and anti vicinal relationships is meaningless. In a general ethane structure there are nine vicinal pairs, some of which are rendered equivalent by the idealized skeletal symmetry. For the (FB)₃ and F₂BFB₂ forms, pairs of vicinal sites are collected into symmetry equivalent sets in Table IV. The alternating (FB)₃ form contains only two different types of vicinal pairs: those separated by two intervening ligands in the Newman projection (anti) and those which are proximal (gauche). For the nonalternating F₂BFB₂ form, there are six sets of symmetry equivalent vicinal interactions. The methine H's in the calculated structures **1f** and **2** are separated by two bonds in the Newman projection and thus belong to the set {25}.

Regardless of the form of the Newman projection, vicinal relationships can be described by use of the Klyne-Prelog system,³³ since this classification scheme depends solely on the numerical value of the appropriate torsional angle. The EFF results described above illustrate the necessity of considering anti-clinal (such as are present in the calculated structures **1f** and **2**) as well as syn-clinal ("gauche") relationships when interpreting small ³J_{HH} values, especially in strained molecules.

Table IV. Sets of Symmetry Equivalent Vicinal Pairs in Alternating and Nonalternating Forms of Ethane

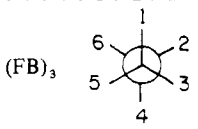
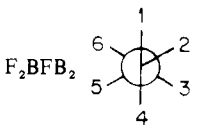
Newman projection	Idealized skeletal symmetry	Sets of symmetry equiv vicinal pairs ^a
 (FB) ₃	D _{3d}	(2) {14,36,52} (0) {12,16,32,34,54,56}
 F ₂ BFB ₂	C ₂	(2) {25} (1) {15,26}, {13,46} (0) {16}, {43}, {23,45}

^aThe parenthesized figure gives the number of intervening ligands in the planar projection.

Other Structures. Compounds **2** and racemic **1** are thus far the sole representatives of a class of noneclipsed ethanes which do not have (FB)₃ ground states, but other examples can be anticipated. We merely note here that eclipsing in ground states is enforced by a cyclopropane ring; that is, when the view is along one C-C bond of the ring, the bonds to the third carbon are forced to be eclipsed. While the ground state of cyclopropane³⁴ is E₃, projections down the 1-2 and 1-3 bonds of a 1,1-disubstituted cyclopropane (**3**) are presumably of the F₂BEB type since the geminal repulsions between substituents on the 1 position are expected (by symmetry) to differ from those on the 2 (or 3) positions. The projection down the 1-2 bond of a 1,1,2,2-tetrasubstituted cyclopropane (**4**) could be of the (FB)₂E type if the molecule twists to alleviate vicinal repulsions. A substituted bicyclobutane structure (**5**) might adopt an FBE₂ conformation for a similar reason. Ground states of ethanes with projections of the types F₃B₃, F₂B₂E, and FEBE pose a more serious challenge to the imagination.

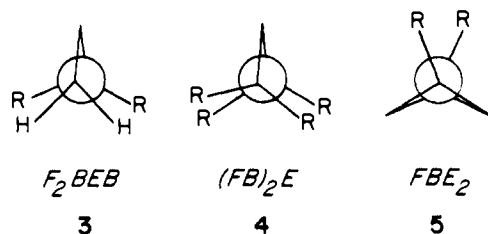

The Newman projections of non-ethane-like structures can also be described by a nomenclature similar to that for ethanes. For example, while ethylene has an E₂ projection, distorted ethylenes³⁵ can be twisted, (FB)₂, or folded, F₂B₂. As a further extension,³⁶ the different conformations (**6a-c**) of 1,1',2,2',3,3'-hexamethylferrocene can be described in terms of ethane-like Newman projections if the unsubstituted ring positions are ignored.

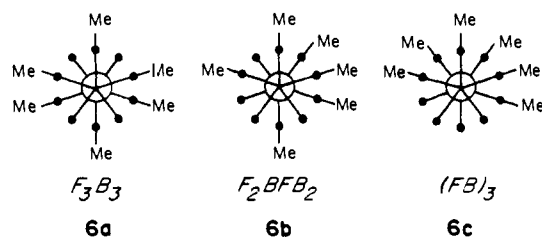

General Group Theoretical Description

The enumeration and description of Newman projections which are topologically distinct (in 2-space) can be generalized to include structures with any number of substituents on each

Table V. Number (*Z*) of Topologically Distinct Newman Projections for Various Values of *m*, *n*, and *p*

No. of ligands		<i>Z</i>					∑ _{<i>p</i>} <i>Z</i> _{<i>m,n</i>}
<i>m</i>	<i>n</i>	<i>p</i> = 0	1	2	3	4	
1	1	1	1	—	—	—	2
2	1	1	1	—	—	—	2
3	1	1	1	—	—	—	2
2	2	2	1	1	—	—	4
4	1	1	1	—	—	—	2
3	2	2	2	1	—	—	5
5	1	1	1	—	—	—	2
4	2	3	2	2	—	—	7
3	3	3	3	2	1	—	9
6	1	1	1	—	—	—	2
5	2	3	3	2	—	—	8
4	3	4	6	4	1	—	15
7	1	1	1	—	—	—	2
6	2	4	3	3	—	—	10
5	3	5	9	6	2	—	22
4	4	7	7	8	2	1	25

end of the central bond. In this section we present a group theoretical approach which serves to enumerate and generate the various Newman projections.

Consider the general system in which *m* and *n* (*m* ≥ *n*) are the number of ligands at each end of the molecular skeleton.

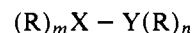

The Newman projections in the absence of eclipsed pairs are topologically similar to (*m* + *n*)-gons with *m* vertices designated F (front) and *n* vertices designated B (back). For example (*m* = *n* = 3):



If there are *p* pairs of eclipsed bonds (*p* ≤ *n*), the Newman projections lead to (*m* + *n* - *p*)-gons with *m* - *p* vertices designated F, *n* - *p* vertices designated B, and *p* vertices designated E (eclipsed). For example (*m* = *n* = 3, *p* = 1):



Thus, there exists a 1:1 correspondence between topologically distinct Newman projections and the distinct configurations ("isomers") of an F_{*m-p*}B_{*n-p*}E_{*p*} substituted (*m* + *n* - *p*)-gon. These projections can therefore be enumerated by counting the isomers of the corresponding polygons. Ruch and co-workers have shown³⁷ that the isomers of a structure with skeletal symmetry *R* and equivalent ligand symmetry *L* correspond to double cosets of the group consisting of all ligand permutations (*P*) decomposed by its subgroups *R* and *L*, i.e., of the form³⁸ *R|P|L*. In the present context, the appropriate groups³⁹ are: (1) *R* = the two-dimensional skeletal symmetry of the (*m* + *n* - *p*)-gon ≅ *D*_{*m+n-p*} (for *m* + *n* - *p* > 2); (2) *P* = the group of permutations of the vertices of the (*m* + *n* - *p*)-gon ≅ *S*_{*m+n-p*}; (3) *L* = equivalent ligand symmetry, i.e., the subgroup of *P* containing permutations of identically labeled (F,B,E) vertices. If *m* ≠ *n*, *L* ≅ *S*_{*m-p*} × *S*_{*n-p*} × *S*_{*p*}. If *m* = *n*, the labels front and back are arbitrary; therefore, permutations which exchange all of the F vertices with all of the B vertices must be included, so that *L* ≅ (*S*_{*m-p*} × *S*_{*n-p*}) ∧ *S*₂ × *S*_{*p*} ≅ *S*₂[*S*_{*m-p*}] × *S*_{*p*}.

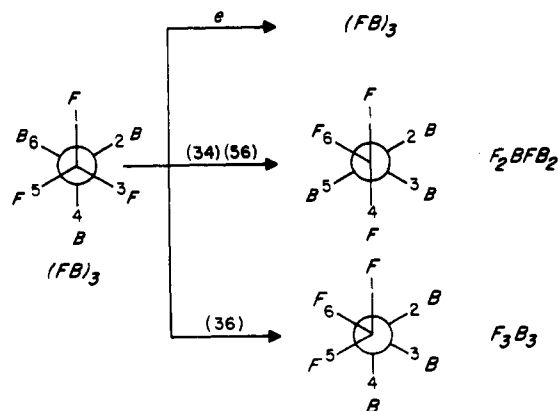

Figure 5. Illustration of the use of double coset representatives for the generation of the noneclipsed, ethane-like ($m = n = 3, p = 0$) Newman projections from a given reference structure, $(FB)_3$.

The number (Z) of these double cosets, and therefore the number of topologically distinct Newman projections, is given by the formula³⁷

$$Z = \frac{|P|}{|R||L|} \sum_{r=1}^k \frac{|R \cap C_r||L \cap C_r|}{|C_r|}$$

where C_r is one of the k conjugacy classes of P .⁴⁰ Values of Z for each combination of m , n , and p ($m + n \leq 8$) are given in Table V.

Given the choice of one Newman projection as a reference structure for particular values of m , n , and p , the other distinct Newman projections can be generated by use of these double cosets. The groups R , P , and L can be written as permutations of $m + n - p$ ligands (labeled F, B, and E) on a skeleton with numbered sites. Using the convention that permutations act on site labels, R and P are independent of the ligand labels, i.e., of the particular projection, whereas L is not. Let us designate L for the reference structure as L_0 . Given a set of permutations which includes a representative permutation from each double coset $R|P|L_0$, all of the distinct projections (for those particular values of m , n , and p) can be generated. For example, for the case with $m = n = 3, p = 0$ (three double cosets, cf. Table V), and using $(FB)_3$ as the reference structure (with site labeling as in Table IV), a set of double coset representatives is $\{e = (1)(2)(3)(4)(5)(6), (34)(56), (36)\}$. As shown in Figure 5, the action of these three permutations on the reference structure results in the three noneclipsed ethane forms.⁴¹ The equivalent ligand symmetry group of the i th Newman projection (L_i) generated from the reference structure by the double coset representative p_i is given by $p_i L_0 p_i^{-1}$.

A description of the possible Newman projections up to and including $m + n = 8$ appears in the Supplementary Material.

Acknowledgment. We thank the National Science Foundation (CHE74-18161) for support of this work. One of us (D.A.D.) thanks the Allied Chemical Corp. for a predoctoral fellowship.

Supplementary Material Available: Calculated Cartesian coordinates for structure 1f and a tabulation of all possible topologically distinct Newman projections up to and including $m + n = 8$ with FBE designations (10 pages). Ordering information is given on any current masthead page.

References and Notes

- For example, see E. L. Ellef, N. L. Allinger, S. J. Angyal, and G. A. Morrison, "Conformational Analysis", Wiley-Interscience, New York, N.Y., 1965, Chapter 1.
- K. R. Hanson, *J. Am. Chem. Soc.*, **86**, 2731 (1966).
- Symmetry nonequivalence is a necessary but not a sufficient condition

for differences in scalar properties, since accidental equivalence cannot be ruled out on grounds of logic. However, the probability of such an event becomes vanishingly small as the limits of experimental error become vanishingly small.

- Although it is easy to devise enantiomorphous itineraries connecting successive energy minima, the discussion is much simplified by assuming an achiral midpoint.
- For the rotation itinerary shown in Figure 2b, the only symmetry-unique points are the E_3 structure (C_{2v}) and the $(FB)_3$ structure with C_2 symmetry ($\phi = \pm\pi$). These structures can therefore be associated with energy extrema, presumably a transition state and an energy minimum, respectively. All other conformations, including the $(FB)_2E$ and FBE_2 structures, have C_2 symmetry. Given the infinite number of C_2 structures involved, the probability is vanishingly small that a structure with one or two pairs of bonds exactly eclipsed corresponds to a transition state. In other words, the transition state connecting the C_{2h} minimum with either one of the two C_2 minima most probably has no bonds eclipsed, contrary to popular supposition.
- In our discussions of rotation itineraries, we have ignored F_3B_3 structures since their existence is not required by symmetry and furthermore seems unlikely from a chemical point of view. We also assume that all nine dihedral angles about the ethane central bond increase or decrease monotonically throughout the torsional circuit.
- S. Brownstein, J. Dunogues, D. Lindsay, and K. U. Ingold, *J. Am. Chem. Soc.*, **99**, 2073 (1977).
- (a) P. Finocchiaro, D. Gust, W. D. Hounshell, J. P. Hummel, P. Maravigna, and K. Mislow, *J. Am. Chem. Soc.*, **98**, 4945 (1976); (b) D. A. Dougherty, K. Mislow, J. F. Blount, J. B. Wooten, and J. Jacobus, *ibid.*, **99**, 6149 (1977); (c) D. A. Dougherty, F. M. Llori, K. Mislow, and J. F. Blount, *Tetrahedron*, in press.
- H. H. Huang, *Aust. J. Chem.*, **29**, 2415 (1976).
- F. Heinrich and W. Lüttke, *Chem. Ber.*, **110**, 1246 (1977).
- H.-D. Beckhaus, G. Hellmann, and C. Rüchardt, *Chem. Ber.*, **111**, 72 (1978). We thank Professor Rüchardt for providing us with a copy of this paper prior to publication.
- W. D. Hounshell, D. A. Dougherty, J. P. Hummel, and K. Mislow, *J. Am. Chem. Soc.*, **99**, 1916 (1977).
- A. J. M. Reuvers, A. Sinnema, F. van Rantwijk, J. D. Remijnse, and H. van Bekkum, *Tetrahedron*, **25**, 4455 (1969).
- M. Karplus, *J. Chem. Phys.*, **30**, 11 (1959); *J. Am. Chem. Soc.*, **85**, 2870 (1963). See also F. A. Bovey, "Nuclear Magnetic Resonance Spectroscopy", Academic Press, New York, N.Y., 1969, p 355 ff; L. M. Jackman and S. Sternhell, "Applications of Nuclear Magnetic Resonance Spectroscopy in Organic Chemistry", 2nd ed, Pergamon Press, Oxford, 1969, Chapter 4-2.
- N. L. Allinger, M. T. Tribble, M. A. Miller, and D. H. Wertz, *J. Am. Chem. Soc.*, **93**, 1637 (1971).
- J. D. Andose and K. Mislow, *J. Am. Chem. Soc.*, **96**, 2168 (1974).
- The program STRAIN is available from QCPE (No. 348), Department of Chemistry, Indiana University, Bloomington, Ind.
- J. F. Blount and K. Mislow, *Tetrahedron Lett.*, 909 (1975).
- E. M. Engler, J. D. Andose, and P. v. R. Schleyer, *J. Am. Chem. Soc.*, **95**, 8005 (1973).
- All the input structures had the following initial values ($e =$ ethane, $x =$ ring carbon of xylol group, $b =$ quaternary carbon of *tert*-butyl group, $m =$ methyl): $C_e-C_e = 1.59$ Å; $C_e-C_x = 1.55$ Å; $C_e-C_b = 1.56$ Å; $C_x-C_m = 1.54$ Å; $C_b-C_m = 1.55$ Å; $C_e-C_e-C_x = C_e-C_e-C_b = 112.0^\circ$; $C_m-C_b-C_m = 109.5^\circ$; regular hexagonal aryl rings with $C_x-C_x = 1.39$ Å and a dihedral angle ($C_e-C_e-C_x-C_x$) of 45.0° ; perfect staggering of substituents around all other bonds.
- While this value certainly exceeds that of a normal C-C bond, it is by no means exceptional for a highly strained structure (see ref 12).
- For details of structure 1f, see paragraph at end of paper regarding supplementary material.
- One end of the minimized structure (1f) was rotated to give a higher energy structure with regular front-back alternation ($(FB)_3$ Newman projection). Relaxation of this new structure returned it to the minimum represented by 1f. This finding, coupled with the fact that the initial minimization proceeded along a path in which the absolute value of the H-C_e-C_e-C_b dihedral angle was constantly decreasing, leads us to conclude that 1f represents a true minimum and not just a point along a very shallow potential.²⁴ Except for this molecule, the usual procedure²⁵ of varying dihedral angles of the minimum energy structure and allowing the new structure to relax was not carried out since the torsional potentials of highly congested molecules such as 1 are generally not shallow, and, in our experience, additional precautionary measures^{24,25} (which for structures such as 1 require excessive computation time) are therefore unnecessary.
- D. N. J. White and O. Ermer, *Chem. Phys. Lett.*, **31**, 111 (1975).
- L. D. Iroff and K. Mislow, *J. Am. Chem. Soc.*, **100**, 2121 (1978).
- A structure corresponding to the minimum reported by Rüchardt and co-workers¹¹ with the Allinger 1971 force field was used as an input structure for the other three force fields. The resulting structures are those reported in Table III. Since the MUB-2 minimum exhibited an $(FB)_3$ Newman projection, this structure ($\alpha = -11.5^\circ$) was used as an input structure for the two Allinger and the Schleyer force fields. Using the Schleyer force field a nearly eclipsed (but strictly speaking $(FB)_3$, $\alpha = -0.7^\circ$) conformation resulted, whereas the Allinger 1971 force field led to the F_2BFB_2 conformation ($\alpha = 2.3^\circ$). Use of the Allinger 1973 force field did not lead to a stable structure, since the already extended bonds continued to lengthen without limit, owing to the cubic term in the stretching potential (cf. also ref 25, footnote 44).
- D. H. Wertz and N. L. Allinger, *Tetrahedron*, **30**, 1579 (1974).
- S. Fitzwater and L. S. Bartell, *J. Am. Chem. Soc.*, **96**, 5107 (1976). See also footnote 4 in L. S. Bartell, *J. Am. Chem. Soc.*, **99**, 3279 (1977).
- H.-D. Beckhaus and C. Rüchardt, *Chem. Ber.*, **110**, 878 (1977).
- Values for C_e-C_b angles, average C-C bond lengths, and C_e-C bond

lengths are: experimental,³¹ 125–128 (6)°, 1.545 (5) Å, not determined; Allinger 1971, 126.9°, 1.541 Å, 1.552 Å; Allinger 1973, 128.6°, 1.546 Å, 1.548 Å; Schleyer, 126.7°, 1.540 Å, 1.551 Å; MUB-2, 122.6°, 1.541 Å, 1.552 Å.

- (31) L. S. Bartell and W. F. Bradford, *J. Mol. Struct.*, **37**, 113 (1977).
 (32) G. P. Hellmann, Ph.D. Thesis, Universität Frelburg, 1977, p 45.
 (33) W. Klyne and V. Prelog, *Experientia*, **16**, 521 (1960).
 (34) O. Bastlansen, F. N. Frltsch, and K. Hedberg, *Acta Crystallogr.*, **17**, 538 (1964).
 (35) J. F. Liebman and A. Greenberg, *Chem. Rev.*, **76**, 311 (1976); cf. pp 329–330.

- (36) We thank Dr. Paul Bickart for this suggestion.
 (37) E. Ruch, W. Hässelbarth, and B. Richter, *Theor. Chim. Acta*, **19**, 288 (1970); W. Hässelbarth and E. Ruch, *Ibid.*, **29**, 259 (1973).
 (38) J. G. Nourse, *J. Am. Chem. Soc.*, **99**, 2063 (1977).
 (39) For notation, cf. J. G. Nourse and K. Mislow, *J. Am. Chem. Soc.*, **97**, 4571 (1975).
 (40) The conjugacy classes of S_n and the cycle structure of the wreath products necessary for L can be found in D. E. Littlewood, "The Theory of Group Characters", Clarendon Press, Oxford, 1940, pp 265–284.
 (41) Note that (34)(56) yields *si*-F₂BFB₂. A representative of that double coset could equally well have been chosen to give *re*-F₂BFB₂ (e.g., (23)(45)).

Strained Small Ring Compounds. Structure of a Substituted Semibullvalene, 1-Cyanotricyclo[3.3.0.0^{2,8}]octa-3,6-diene. Geometric Evidence for Homoaromaticity in the Molecular Ground State

Gary G. Christoph* and Mark A. Beno

Contribution from the Evans Chemical Laboratories, Chemistry Department, Ohio State University, Columbus, Ohio 43210. Received September 7, 1977

Abstract: The structure of 1-cyanosemibullvalene (1-cyanotricyclo[3.3.0.0^{2,8}]octa-3,6-diene, C₉H₇N) has been determined by high-resolution x-ray crystallographic methods at -45 °C. The molecule exists wholly in the tautomeric form possessing the cyclopropane ring C(1)–C(2)–C(8). The extraordinarily long C(2)–C(8) bond distance (1.577 Å, corrected for thermal libration) and the shortened distance between the formally nonbonded atoms C(4) and C(6) (2.35 Å), together with the lack of indication of severe repulsive strain, are evidence for a small but significant homoaromatic stabilization in the molecule. The interaction between C(4) and C(6) is accordingly deduced to be attractive, however with an estimated bond order of no more than 0.10 for the p–p σ overlap between these two atoms. 1-Cyanosemibullvalene forms colorless, prismatic crystals having the orthorhombic space group $P2_12_12_1$. The cell constants are $a = 6.693$ (2), $b = 8.301$ (3), $c = 12.393$ (4) Å (MoK α , $T = -45$ °C). There are four molecules per cell, each possessing nearly perfect noncrystallographic mirror symmetry. The final R factors for 1192 reflections are $R = 0.056$ and $R_w = 0.066$.

Introduction

Small ring hydrocarbons are particularly interesting compounds because their high energy content relative to the acyclic isomers often endows them with unusual reactivity patterns. Occasionally, such compounds are remarkably unreactive and stable, usually because rearrangement to a less highly strained system must go via an even more highly strained state or because direct rearrangements are forbidden by symmetry rules.¹ In either case, the reactivity, or lack of it, is strongly determined by the molecular structure; one is immediately led to the general question of how the "strain" inherent in these molecules is expressed; is it accumulated in one or two bonds or is it distributed throughout the molecule? Further, what is the effect on the strained system (and on its reactivity) of various substituent groups?

Sufficient numbers of small monocyclic hydrocarbons have been examined that the direct substituent effects on such compounds, if not clearly predictable, are at very least regular and understandable in terms of steric, electronic, and inductive effects. More unusual situations arise in which a small ring system is either further strained or constrained by fusion with other small rings. Abnormal molecular geometries can be generated in this fashion and the reactivity patterns of these and similar compounds have attracted much synthetic and kinetic attention.² In this and subsequent papers we will examine the structures of highly strained polycyclic hydrocarbons with the aim of finding the structural bases for their reactivities.

The bridged homotropilidenes bullvalene (I), dihydrobullvalene (II), barbaralane (III), and semibullvalene (IV) are

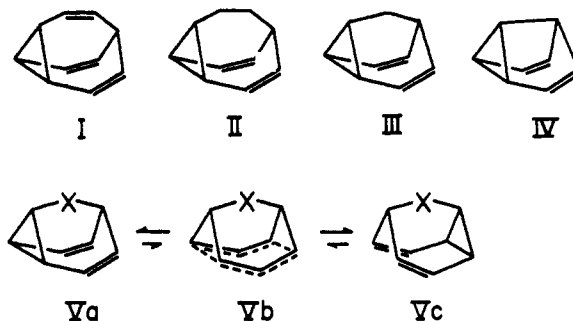

fluxional in the sense that internal Cope rearrangements (e.g., $Va \rightleftharpoons Vc$) are fairly facile, with calculated energies of activation on the order of 3–15 kcal/mol.³ These molecules are of considerable current interest because the transition states of such rearrangements are in theory homoaromatic, and the possibility exists of preferentially stabilizing the transition state relative to the ground state in molecules of this type with appropriate substituents⁴ and of thus isolating the first derivatives of bishomobenzene (VI).



Cheng, Anet, Mioduski, and Meinwald⁵ have recently measured the free energy of activation for the degenerate Cope